

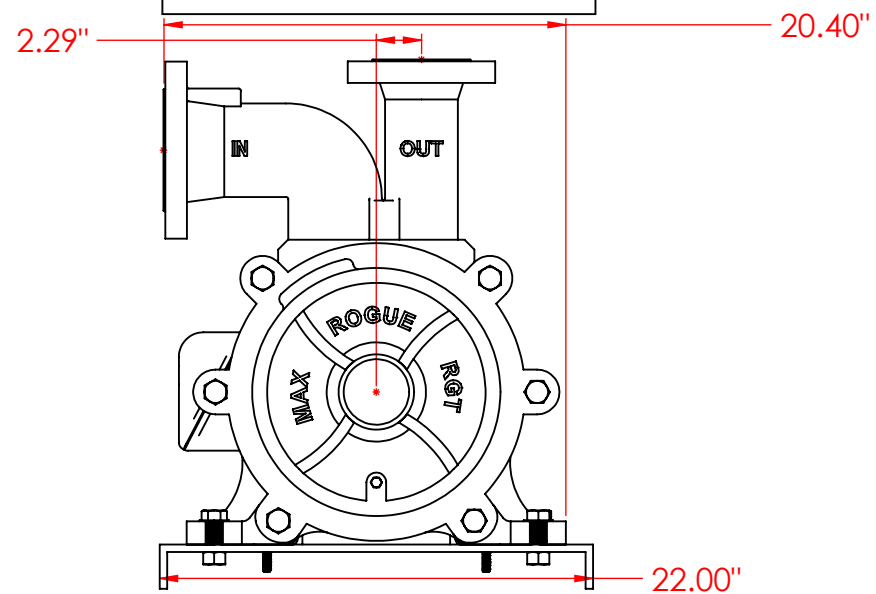

Model: MAX RGT-120FS	
Flow Rate	120 gpm
Air Flow Rate	96 cfh
Seal Type	Mechanical
Weight	920 lbs
Fittings	
Inlet	4" Flange
Outlet	3" Flange
Air Inlet	.25" NPT
Materials	
Impeller	316 SS
O-Ring	Viton
Mechanical Seal	Viton
Body	304 SS
Motor	
Speed	1750 rpm
Horsepower	20 hp
Efficiency @100% Load	Premium,93.0%

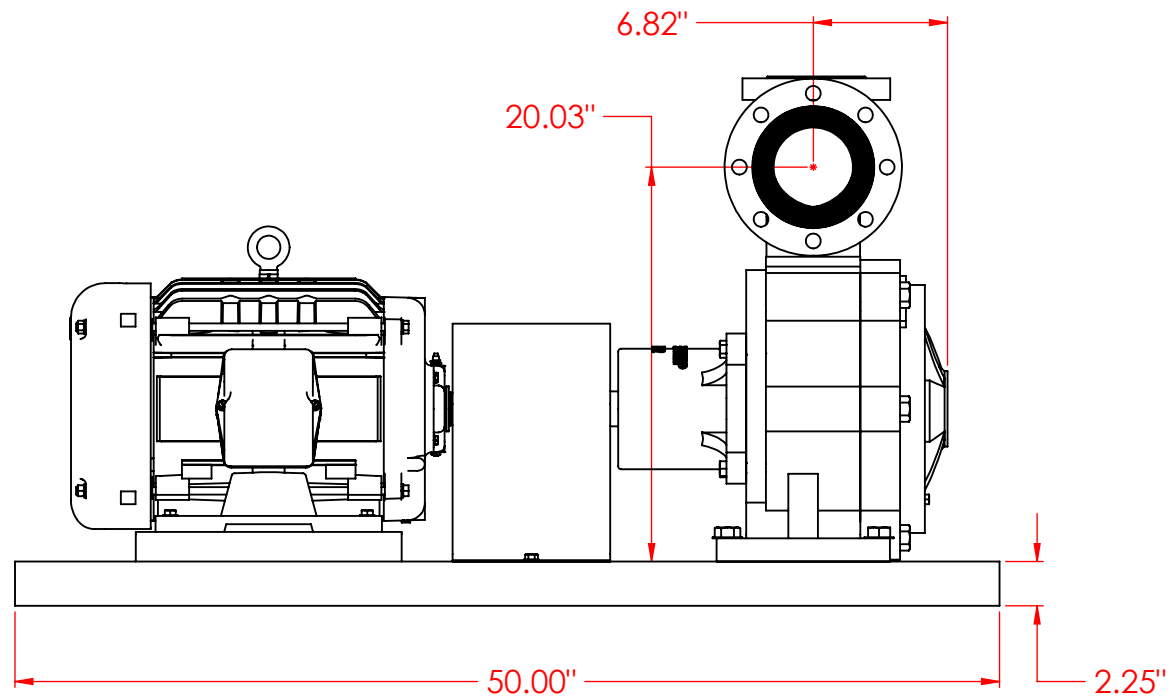

REV	REVERSION DESCRIPTION	DATE	SIGNATURE

CUSTOMER: Sales Model		 Rogue Pump Company, LLC 19215 SE 34th Street Suite 106-202 CAMAS, WA 98607	
<small>THE INFORMATION HEREIN IS PROPRIETARY TO ROGUE PUMP COMPANY, LLC. NO PORTION OF IT SHALL BE COPIED, DISCLOSED OR USED FOR DESIGN OR MANUFACTURE EXCEPT WITH SPECIFIC WRITTEN CONSENT FROM ROGUE PUMP COMPANY</small>		TITLE: MAX RGT-120FS	
DRAWN BY: REW	DRAWING NO. R-120-S001	DRAWING SIZE B	REV
CERTIFIED:	DATE: 6/21/17	SCALE: 1:7	SHEET: 1 of 1

CONFIDENTIAL