

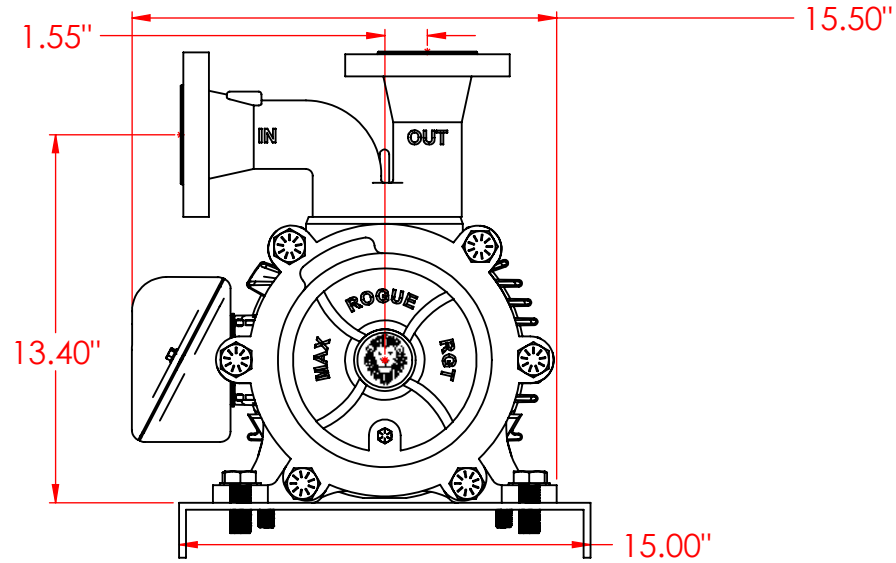

<b>Model: MAX RGT-50FI</b>	
Flow Rate	50 gpm
Air Flow Rate	40 cfm
Seal Type	Mechanical
Weight	350 lbs
<b>Fittings</b>	
Inlet	2" Flange
Outlet	2" Flange
Air Inlet	.25" NPT
<b>Materials</b>	
Impeller	C. Steel
O-Ring	Viton
Mechanical Seal	Viton
Body	Ductile Iron
<b>Motor</b>	
Speed	1750 rpm
Horsepower	7.5 hp
Efficiency @100% Load	Premium, 91.7%

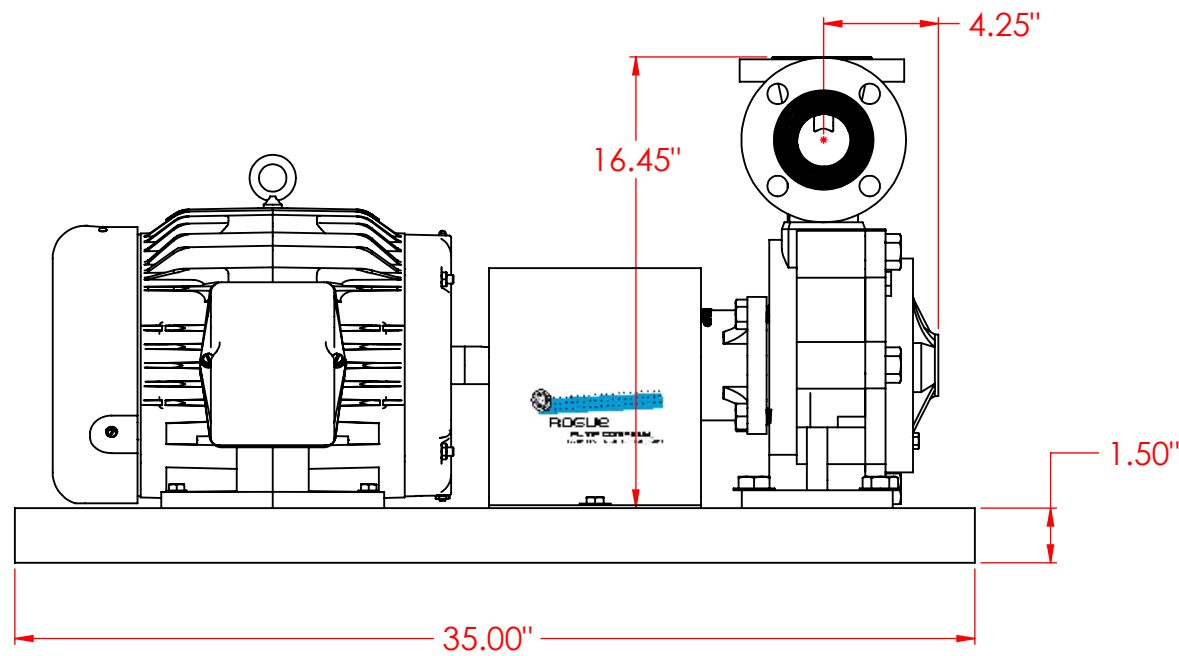

REV	REVISION DESCRIPTION	DATE	SIGNATURE

CUSTOMER: Sales Model		 Rogue Pump Company, LLC 19215 SE 34th Street Suite 106-202 CAMAS, WA 98607	
<small>THE INFORMATION HEREIN IS PROPRIETARY TO ROGUE PUMP COMPANY, LLC. NO PORTION OF IT SHALL BE COPIED, DISCLOSED OR USED FOR DESIGN OR MANUFACTURE EXCEPT WITH SPECIFIC WRITTEN CONSENT FROM ROGUE PUMP COMPANY</small>		TITLE: <b>MAX RGT-50FI</b>	
DRAWN BY: REW	DRAWING NO. R-50-S001	DRAWING SIZE <b>B</b>	REV
CERTIFIED:	DATE: 6/19/17	SCALE: 1:7	SHEET: 1 of 1

**CONFIDENTIAL**