

8

7

6

5

4

3

2

1

D

D

C

C

B

B

A

A

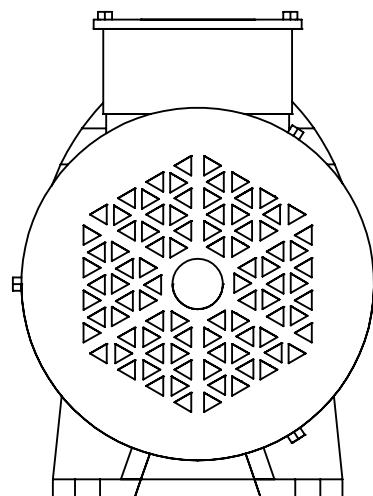
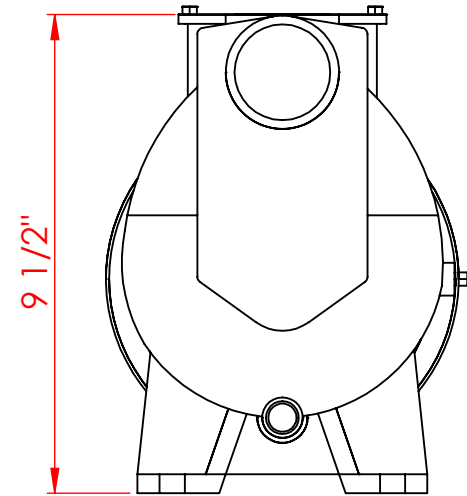
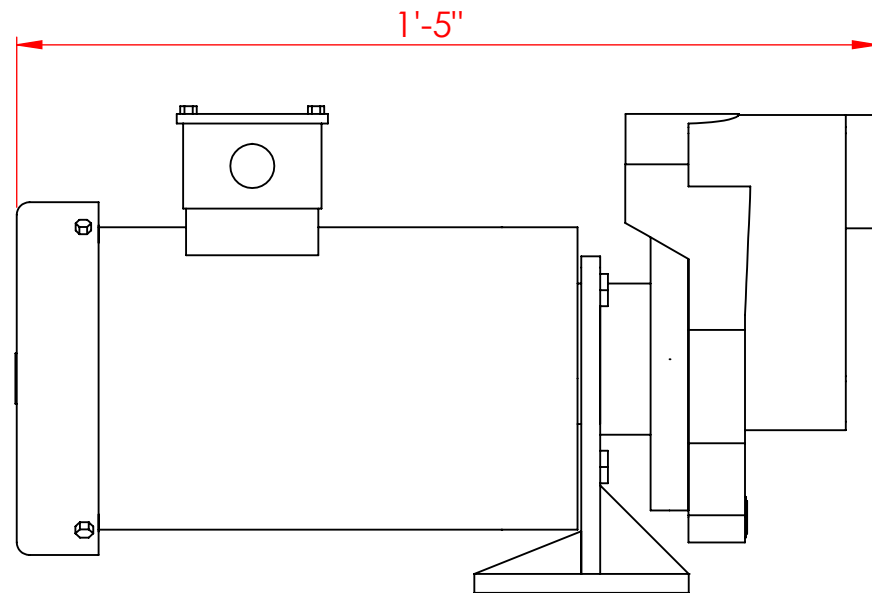
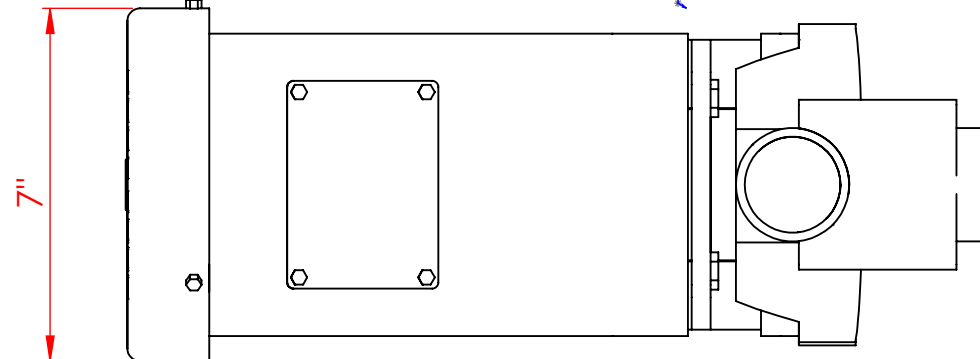
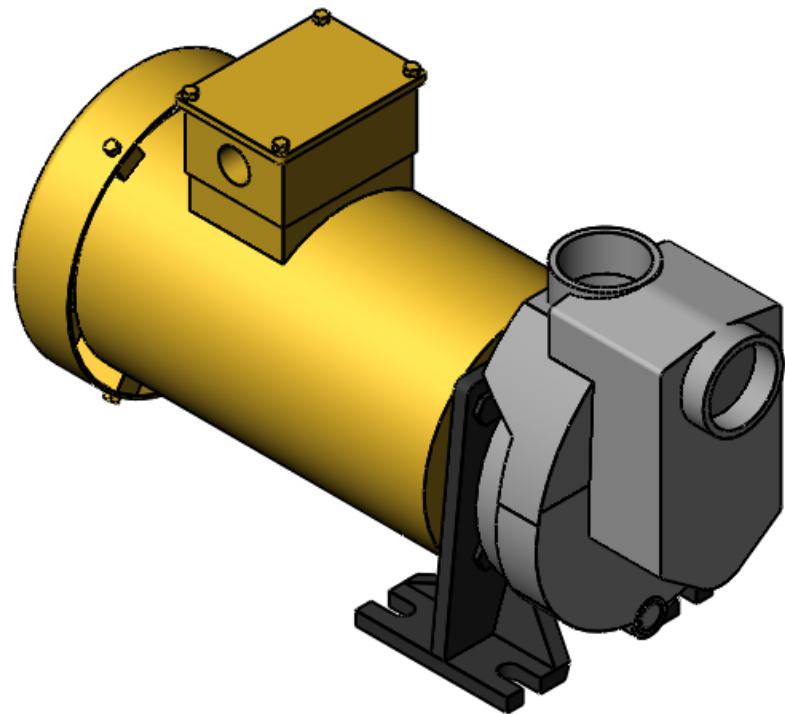

**MAX TRS-50
Pump Specifications**

Capacity:

49 GPM

Dimensions:

Length - 17"
Width - 7"
Height - 9 1/2"

Weight:

Dry - Approx. 42 lbs

Motor:

.5 HP 3P 60Hz TEFC

Piping:

Inlet - 1 1/2"
Outlet - 1 1/2"

REV	REVISION DESCRIPTION	DATE	SIGNATURE

CUSTOMER: Sales Model		 Rogue Pump Company, LLC 19215 SE 34th Street Suite 106-202 CAMAS, WA 98607	
<small>THE INFORMATION HEREIN IS PROPRIETARY TO ROGUE PUMP COMPANY, LLC. NO PORTION OF IT SHALL BE COPIED, DISCLOSED OR USED FOR DESIGN OR MANUFACTURE EXCEPT WITH SPECIFIC WRITTEN CONSENT FROM ROGUE PUMP COMPANY</small>		TITLE: MAX TRS-50	
DRAWN BY: REW	CERTIFIED:	DRAWING NO.:	REV
DATE: 2/12/16		SCALE: 1:1.5	SHEET: 1 of 1

CONFIDENTIAL

8

7

6

5

4

3

2

1